

## InGaAs Avalanche Photodiode

### Specifications

#### Absolute Maximum Ratings

Parameter	Symbol	Value	Unit
Forward current	$I_F$	10	mA
Reverse current	$I_R$	2	mA
Operating temperature	$T_{opr}$	-40 to +85	°C
Storage temperature	$T_{stg}$	-40 to +85	°C

#### Electrical and Optical characteristics (Ta=25°C unless otherwise noted)

Parameter	Symbol	Min.	Typ.	Max.	Unit	Conditions
Active diameter	D	75			μm	
Bandwidth	BW		2.0		GHz	M=10
Responsivity	R	0.80	0.90		A/W	$\lambda=1310\text{nm}$ , M=1
		0.90	1.05			$\lambda=1550\text{nm}$ , M=1
Breakdown voltage	$V_B$	35	45	55	V	$I_D=10\mu\text{A}$
Dark current	$I_D$		15	65	nA	$0.9 \times V_B$
Temperature coefficient of $V_B$	$\Delta V_B/\Delta T$	0.08	0.10	0.12	V/°C	
Chip capacitance	$C_{chip}$		0.54	0.65	pF	f=1MHz
Total capacitance	$C_t$		0.9	1.1	pF	f=1MHz

Specifications are subject to change without notice.

Package

(unit: mm)

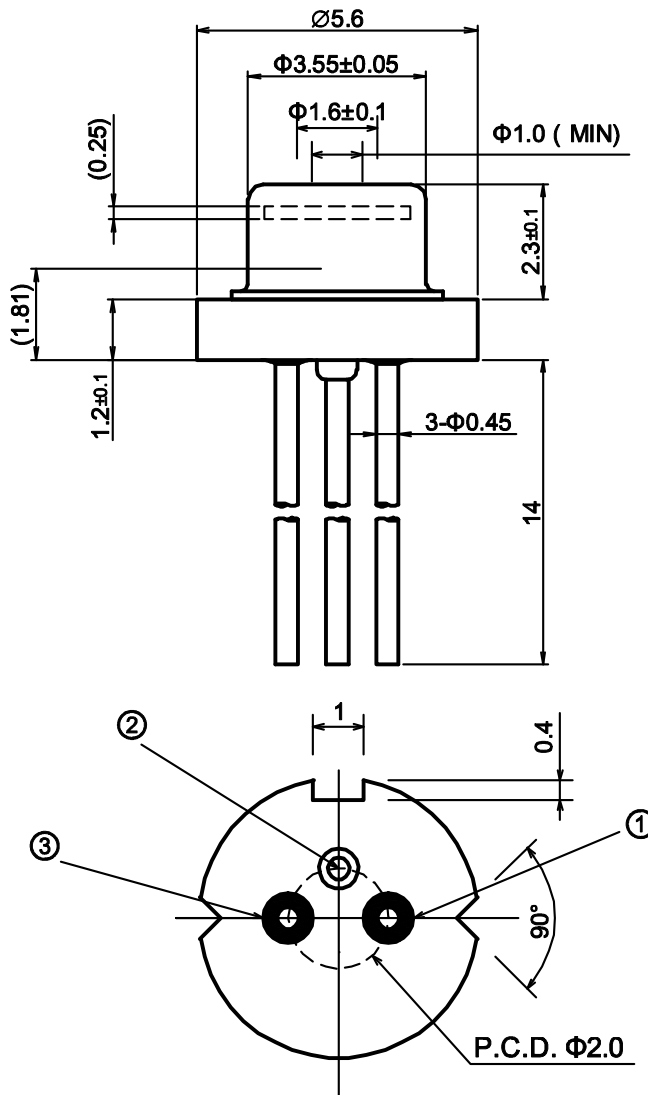

Bottom View

Pin Assignment

- ① anode
- ② case
- ③ cathode

Specifications are subject to change without notice.

Contacts:

[www.kyosemi.co.jp](http://www.kyosemi.co.jp) / [info@kyosemi.co.jp](mailto:info@kyosemi.co.jp)

Kansai Sales Office: 949-2 Ebisu-cho, Fushimi-ku, Kyoto, 612-8201 Japan Tel: +81 75 605 7311 Fax: +81 75 605 7312 (Overseas Sales Dept.)

Tokyo Sales Office: 24<sup>th</sup> Sky Building, 2<sup>nd</sup> Floor, 1-34-3 Shinjuku, Shinjuku-ku, Tokyo 160-0022 Japan Tel: +81 3 5312 5360 Fax: +81 3 5312 5367

Eniwa Operation: 385-31 Toiso, Eniwa-shi, Hokkaido 061-1405 Japan Tel: +81 123 34 3111 Fax: +81 123 34 2110

Kyosemi Opto America Corp: 3003 Bunker Hill Lane, Suite 102, Santa Clara, CA 95054 USA Tel: +1 408 492 1486 Fax: +1 408 492 9843