

2.5Gbps PD-TIA Receiver with Long Focal Length

Features

- A long work distance is available between the PD can and the fiber end for integrating optical parts
- Low noise and high gain transimpedance amplifier built-in to meet OC-48
- 5 pin package available for an independent PD connection

Package drawings are in the next page.

Applications

- Bi-directional, triple-waves and CWDM optical communications
- Spectroscopic and wavelength selective sensors

Specifications

Absolute Maximum Ratings

Parameter	Symbol	Value	Unit
Supply voltage	V_{cc}	-0.5 to 6.0	V
Operating temperature	T_{opr}	-40 to +85	°C
Storage temperature	T_{stg}	-40 to +85	°C

Electrical and Optical characteristics (Ta=25°C unless otherwise noted)

Parameter	Symbol	Min.	Typ.	Max.	Unit	Conditions
Operating voltage	V_{op}	3		5	V	
Supply current	I_{cc}		34	63	mA	
Bit rate	BR		2.5		Gbps	
Bandwidth @-3dB	BW		2.0		GHz	$R_L=50\Omega$, $P_i=-10dBm$, small signal modulation
Optical sensitivity	P_{min}		-22.5		dBm	differential, BER=10 ⁻¹⁰
Output impedance	Z_o	48	50	52	Ω	single ended
Differential output voltage	V_o		323	633	mVpp	$R_L>500\Omega$, single
Noise equivalent power	NEP			916	nWrms	
Photo-electric conversion efficiency	η_{PE}	0.84	1.17		kV/W	single ended, $R_L>500\Omega$

Specifications are subject to change without notice.

Package Options

Dimensions (unit: mm)

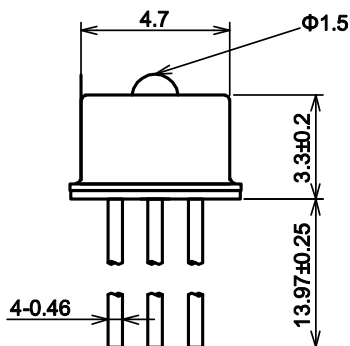

Side view

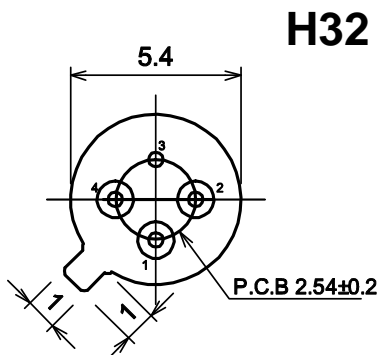

Bottom view

Pin assignment

KPDX2GD-H32	
PIN	Function
1	V _{CC}
2	OUT
3	GND
4	OUTB

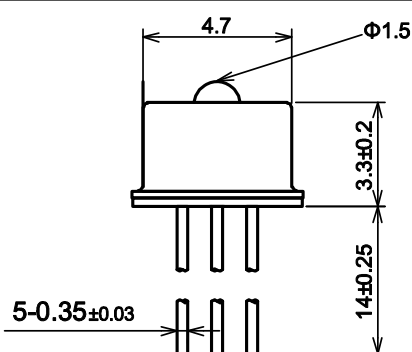

Side view

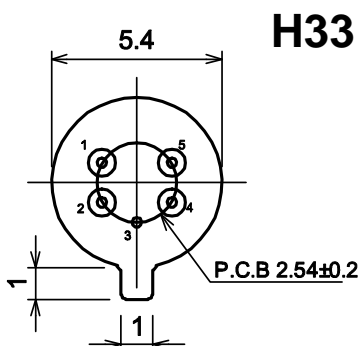

Bottom view

KPDX2GD-H33	
PIN	Function
1	V _{PD}
2	OUT
3	GND
4	OUTB
5	V _{CC}

Collimated beam coupling

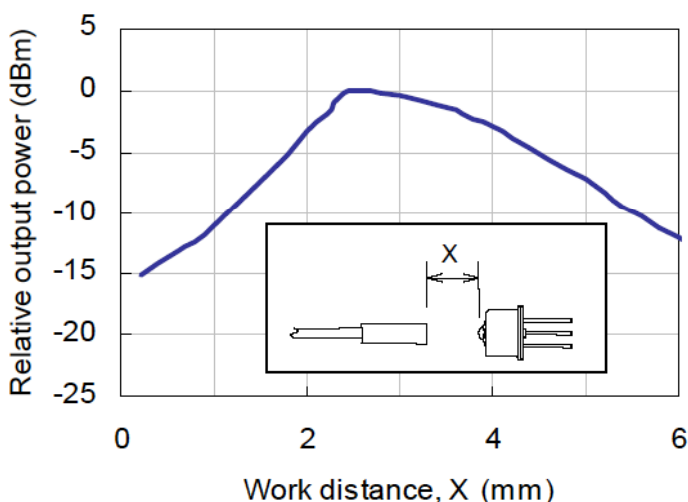

Bit error rate

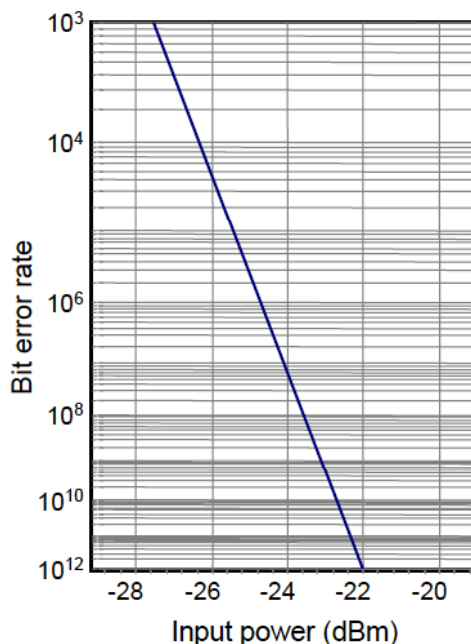

Specifications are subject to change without notice.

Contacts:

Kansai Sales Office: 949-2 Ebisu-cho, Fushimi-ku, Kyoto, 612-8201 Japan Tel: +81 75 605 7311 Fax: +81 75 605 7312 (Overseas Sales Dept.)
Tokyo Sales Office: 24th Sky Building, 2nd Floor, 1-34-3 Shinjuku, Shinjuku-ku, Tokyo 160-0022 Japan Tel: +81 3 5312 5360 Fax: +81 3 5312 5367
Eniwa Operation: 385-31 Toiso, Eniwa-shi, Hokkaido 061-1405 Japan Tel: +81 123 34 3111 Fax: +81 123 34 2110
Kyosemi Opto America Corp: 3003 Bunker Hill Lane, Suite 102, Santa Clara, CA 95054 USA Tel: +1 408 492 1486 Fax: +1 408 492 9843

www.kyosemi.co.jp / info@kyosemi.co.jp