

Si Phototransistor

KPT081M31

Features

- NPN phototransistor
- Transparent epoxy mold
- Low leak current

Applications

- Optical switches
- Optical encoders
- Photo-isolator
- Camera stroboscopes
- Infrared sensors
- Automatic control apparatus

Dimensions (unit: mm)

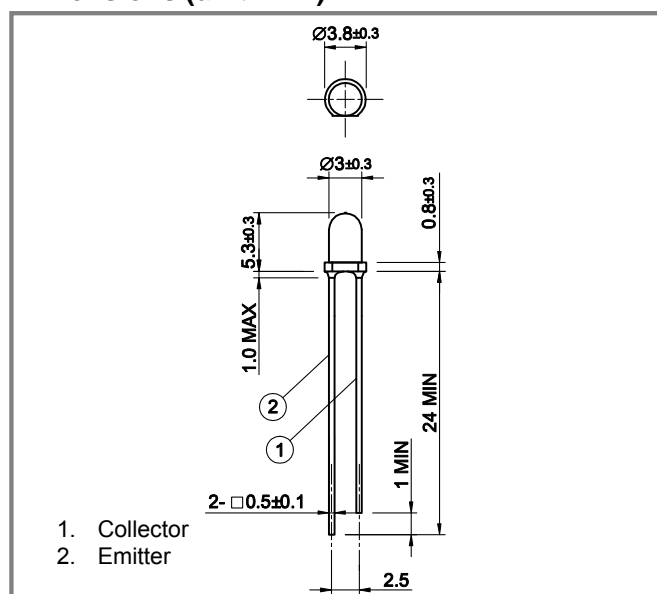

Absolute Maximum Ratings

Parameter	Symbol	Value	Unit	Note
Collector-emitter voltage	V_{ce0}	20	V	
Emitter-collector voltage	V_{eco}	5	V	
Collector-base voltage	V_{cbo}	-	V	
Emitter-base voltage	V_{ebo}	-	V	
Collector dissipation	P_D	75	mW	
Operating temperature	T_{opr}	-25 to +85	°C	Avoid dew condensation
Storage temperature	T_{stg}	-30 to +100	°C	Avoid dew condensation

Electrical and Optical Characteristics (Ta=25 °C unless otherwise noted)

Parameter	Symbol	Min.	Typ.	Max	Unit	Test Conditions
Active area	S	0.64 x 0.64			mm ²	
Sensitive wavelength	λ	400	880(λ_p)	1000	nm	λ_p =Peak wavelength
Photocurrent	I_L	-	7	-	mA	$V_{ce} = 5V$, 1000lx(@2856K)
Dark current	I_{ceo}	-	5	200	nA	$V_{ce} = 20V$
Current amplification factor	h_{FE}	600	-	-		$V_{ce} = 5V$, $I_c=2mA$
Collector-emitter saturation voltage	$V_{ce(sat)}$	-	-	0.4	V	$I_c=1mA$ 1000lx(@2856K)
Rise/fall time	t_r, t_f	-	5	-	μs	$V_{ce} = 5V$, $I_c=2mA, R_L=100\Omega$
Half angle	2θ		60		deg	

Specifications are subject to change without notice.

Collector Dissipation-Ambient Temperature

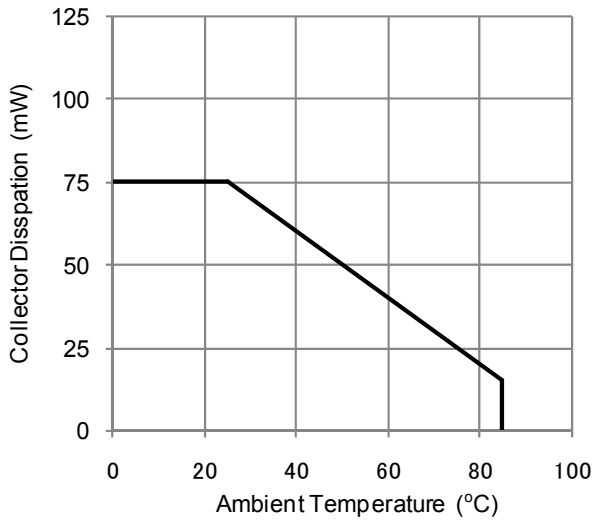

Photocurrent - Collector-Emitter Voltage

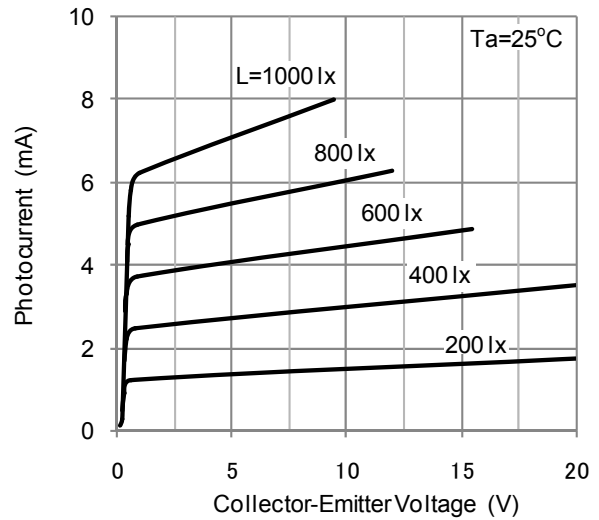

Photocurrent - Illuminance

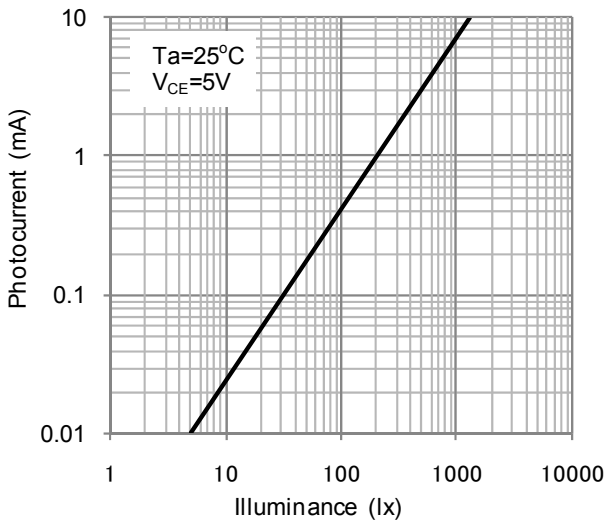

Dark Current - Ambient Temperature

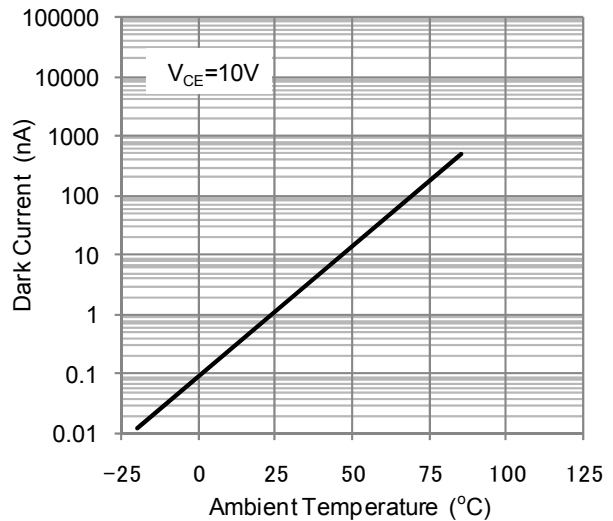

Spectral Responsivity

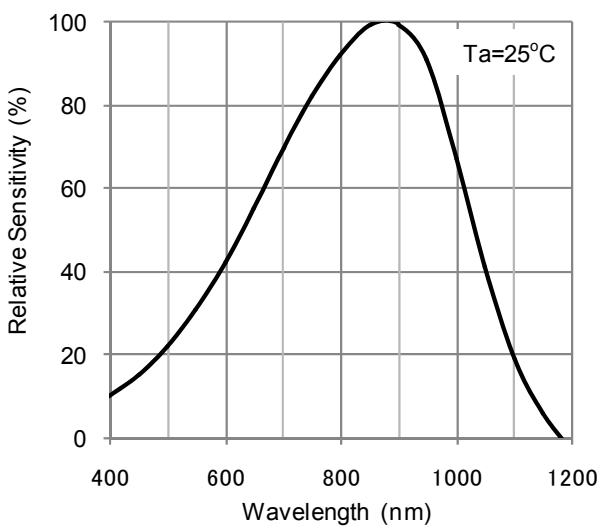

Directivity

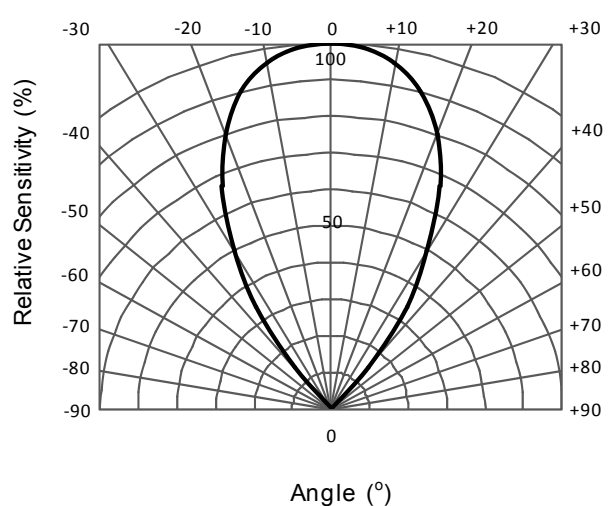

Specifications are subject to change without notice.

Contacts:

www.kyosemi.co.jp / info@kyosemi.co.jp

Kansai Sales Office: 949-2 Ebisu-cho, Fushimi-ku, Kyoto, 612-8201 Japan Tel: +81 75 605 7311 Fax: +81 75 605 7312 (Overseas Sales Dept.)

Tokyo Sales Office: 24th Sky Building, 2nd Floor, 1-34-3 Shinjuku, Shinjuku-ku, Tokyo 160-0022 Japan Tel: +81 3 5312 5360 Fax: +81 3 5312 5367

Eniwa Operation: 385-31 Toiso, Eniwa-shi, Hokkaido 061-1405 Japan Tel: +81 123 34 3111 Fax: +81 123 34 2110

Kyosemi Opto America Corp: 3003 Bunker Hill Lane, Suite 102, Santa Clara, CA 95054 USA Tel: +1 408 492 1486 Fax: +1 408 492 9843