

## KP-M InGaAs Photodiodes for Monitoring

### KPDE030-S

#### Characteristics

- Isolated pins from can (body)
- Small size for high density packaging
- Low capacitance and high speed with a PIN structure
- Low dark current
- High reliability
- Pigtail type available as an option
- Window cap type available (-SW)

#### Applications

- Digital and analog optical communications
- Optical LAN
- OTDR

#### Package

- TO-CAN

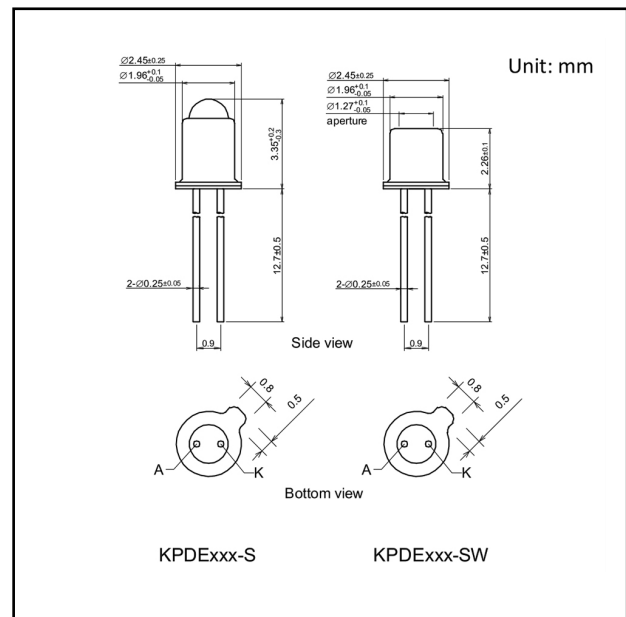

**Absolute Maximum Ratings**

Parameter	Symbol	Value	Unit	Conditions
Reverse voltage	$V_R$	20	V	-
Maximum optical power input	$P_{imax}$	30	mW	-
Forward current	$I_F$	10	mA	-
Operating temperature	$T_{opr}$	-40 to +85		Avoid dew condensation
Storage temperature	$T_{stg}$	-40 to +85		Avoid dew condensation

**Electrical and Optical characteristics** (Ta=25 unless otherwise noted)

Parameter	Symbol	Min.	Typ.	Max.	Unit	Conditions
Active area	S	-	300	-	$\mu\text{m}$	-
Sensitive wavelength		900	-	1700	nm	-
Bandwidth	BW	-	0.6	-	GHz	$R_L=50$ $P_i=-10\text{dBm}$ $V_R=5\text{V}$
Responsivity	R	0.8 0.9	-	-	A/W	$V_R=5\text{V}$ =1310nm $V_R=5\text{V}$ =1550nm
Dark current	$I_D$	-	-	600	pA	$V_R=5\text{V}$
Total capacitance	$C_t$	-	-	6	pF	$V_R=5\text{V}$ f=1MHz

## Notice and Disclaimer

Please note the following points regarding the technical information and product usage described in this document.

1. Information such as product specifications, characteristics, data, specification materials, and structures described in this document is subject to change. Before using our products, make sure to order the latest specifications and check the content. We disclaim warranty unless you use the latest specifications.
2. When considering applications involving heating, such as soldering, especially with eutectic solders, be sure to refer to the latest specifications and check the heat resistance standards.
3. We do not guarantee that your intended use will be satisfied or that our product will comply and operate with the equipment that you use.
4. While the information contained in this document has been carefully prepared for the sake of accuracy, we shall not be liable whatsoever even in the unlikely event that you or a third party suffers damage as a result of the information being incorrect, insufficient, incomplete, or misprinted.
5. Reprinting or reproduction of any part or this entire website without our permission is strictly prohibited.
6. The circuits and usage, etc. included in this document are for reference only. We do not guarantee that there will be no infringement of the intellectual property rights or other rights of the customer or a third party regarding these. We are not liable for any damage related to the infringement of the intellectual property rights or other rights of the customer or a third party.
7. The information contained in this document does not permit the customer to implement or use intellectual property rights or other rights owned or managed by us or a third party.
8. The products included in this document require an extremely high level of reliability, and they are not designed and manufactured for use with equipment or devices (medical equipment, transportation equipment, public transportation equipment, aerospace equipment, nuclear power control devices, fuel control, in-vehicle equipment (excluding car accessories not related to car control), various safety devices, etc.) (hereinafter, "specific application") whose failure or malfunction may cause danger or damage to one's life or health or any other serious damage. We are not liable for any damage caused to you or a third party by using this product or this information for a specific application without obtaining the prior written consent of Kyoto Semiconductor. If you are considering using this product or this information for a specific purpose, please contact our sales office beforehand.
9. For our customers to export this product or the technology we provide, it is necessary to comply with the 'Foreign Exchange and Foreign Trade Act' and the security export control laws and regulations of each country, and follow the procedures stipulated by the said laws and regulations. Do not use this product or this information for purposes such as developing weapons of mass destruction, military use, or other military purposes.
10. This product conforms to the RoHS Directive (2011/65/EU).
11. If you have any inquiries regarding the details of the products described in this document, or if you have any other questions, please feel free to contact us.

## Disclaimer for Sample Products

Kyoto Semiconductor, co. ltd. expressly disclaims any warranty for product samples; development prototypes (engineering samples), and mass production prototypes (pre-production samples). In no event shall Kyoto Semiconductor be liable, whether in contract or in tort, or otherwise, for any damages not only direct or common damages but also any incidental, special, indirect, consequential or punitive damages, including, but not limited to, damages for any loss of use, loss of time, inconvenience, commercial loss, or lost profits, savings or revenues to the fullest extent permitted by law or equity.

By ordering a product sample and subsequently using a product sample, you agree to the terms above.

**KYOSEMI****KYOTO SEMICONDUCTOR Co.,Ltd.**

---

**Kyoto Headquarter  
Kansai Sales Office**307-21, Nishiote-cho, Fushimi-ku, Kyoto, 612-8362, Japan  
TEL:+81 75-605-7314(Kansai Sales Office) FAX:+81 75-605-7312**Tokyo Headquarter  
Tokyo Sales Office**24th Sky Building 2nd and 4th Floor, 1-34-3, Shinjuku Shinjuku-ku, Tokyo, 160-0022, Japan  
TEL:+81 3-5312-5360(Tokyo Sales Office) FAX:+81 3-5312-5367**Kyosemi Opto  
America Corporation**4655, Old Ironsides Suite, 230, Santa Clara, California, 95054, USA  
TEL : +1 408-492-9361 FAX : +1 408-492-9843